

**PROPRIETARY AND CONFIDENTIAL**  
 THE INFORMATION CONTAINED IN THIS DRAWING IS THE SOLE PROPERTY OF ARDENT CONCEPTS, INC.. ANY REPRODUCTION IN PART OR AS A WHOLE WITHOUT THE WRITTEN PERMISSION OF ARDENT CONCEPTS, INC. IS PROHIBITED.

| REVISIONS |                      |        |          |
|-----------|----------------------|--------|----------|
| REV.      | DESCRIPTION          | DATE   | APPROVED |
| A         | RELEASED; ECN11-0819 | 8/4/11 | DJI      |

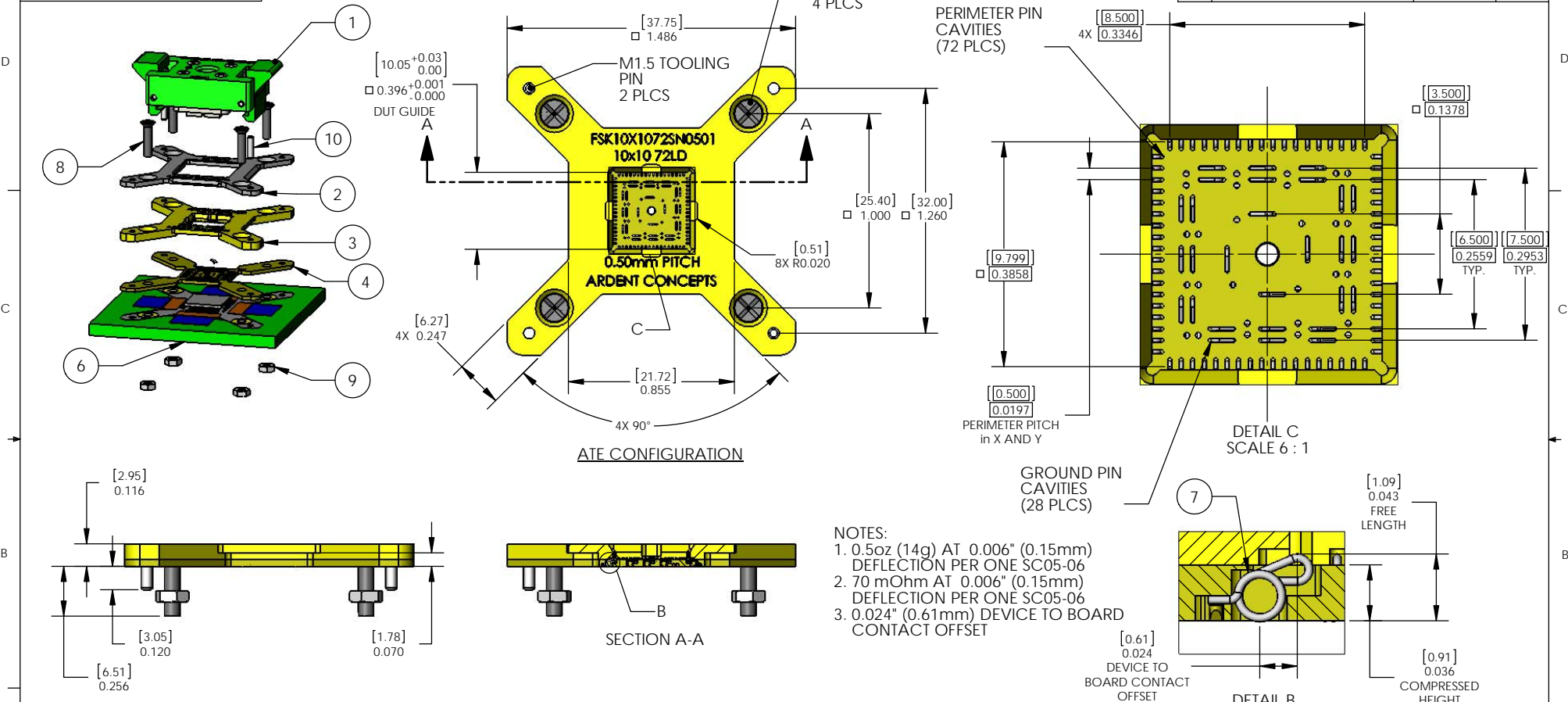

| ITEM NO. | PART NUMBER      | DESCRIPTION                    | Material             | Default/QTY. |
|----------|------------------|--------------------------------|----------------------|--------------|
| 1        | FLD10X10SN01     | HAND TEST LID                  | REF                  | REF          |
| 2        | FAPSN01          | ADAPTER PLATE                  | 303 STAINLESS STEEL  | 1            |
| 3        | FGP10X1072SN0501 | GUIDE PLATE                    | TORLON 4203          | 1            |
| 4        | FIN10X1072SN0501 | INSULATOR                      | TORLON 4203          | 1            |
| 5        | FSCSN01          | SHIPPING COVER                 | ESD LEXAN            | 1            |
| 6        | FFP10X1072SN0501 | FOOTPRINT SPECIFICATION        | REF                  | REF          |
| 7        | SC05-06          | .5mm .005" RC Scrub-R          | SEMI PRECIOUS ALLOY  | 100          |
| 8        | M20FHCS08        | M2 FLAT HEAD X 8mm             | 18-8 STAINLESS STEEL | 4            |
| 9        | M20NUT           | M2 NUT                         | 18-8 STAINLESS STEEL | 4            |
| 10       | M15DP06          | M1.5 X 6mm DOWEL PIN, 9159A005 | HARDENED STEEL       | 2            |

|   |  |  |   |
|---|--|--|---|
| <b>INCH</b><br>UNLESS OTHERWISE SPECIFIED.<br>TOLERANCES:<br>ANGLES: ± 3 X.XX = ± .005<br>X.XXX = ± .002<br>X.XXXX = ± .001 |  | DRAWN: DJI<br>DATE: 8/2/11<br>CHECKED:<br>ENG APPR:  | <br><b>ARDENT CONCEPTS</b><br><small>Manufactured on both coasts of the U.S.</small><br>4 MERRILL INDUSTRIAL DR, SUITE 102<br>HAMPTON, NH 03842<br>(603) 926-2517 |
| CHANGE: MATERIAL<br>NOTE: ---<br>PROJECTION: ---<br>FINISH: ---   | SIZE: <b>B</b><br>TITLE: 10X10, 72LD, 0.50mm SOCKET ASSEMBLY | DWG. NO.: <b>FSK10X1072SN0501</b><br>INTERPRET GEOMETRIC TOLERANCING PER: ANSI Y14.5M 1982 |   |

8 7 6 5 4 3 2 1

**PROPRIETARY AND CONFIDENTIAL**  
 THE INFORMATION CONTAINED IN THIS DRAWING IS THE SOLE  
 PROPERTY OF ARDENT CONCEPTS, INC. ANY REPRODUCTION  
 IN PART OR AS A WHOLE WITHOUT THE WRITTEN PERMISSION OF  
 ARDENT CONCEPTS, INC. IS PROHIBITED.

| REVISIONS |                      |        |          |
|-----------|----------------------|--------|----------|
| REV.      | DESCRIPTION          | DATE   | APPROVED |
| A         | RELEASED; ECN11-0819 | 8/4/11 | DJI      |

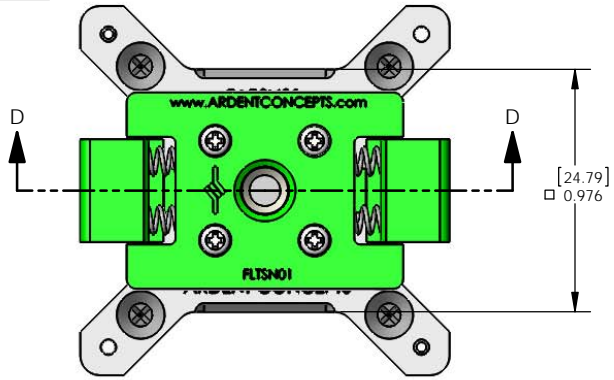

BENCH TEST CONFIGURATION

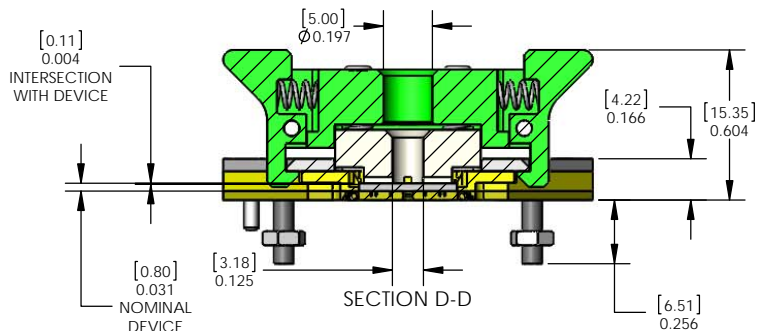

SECTION D-D

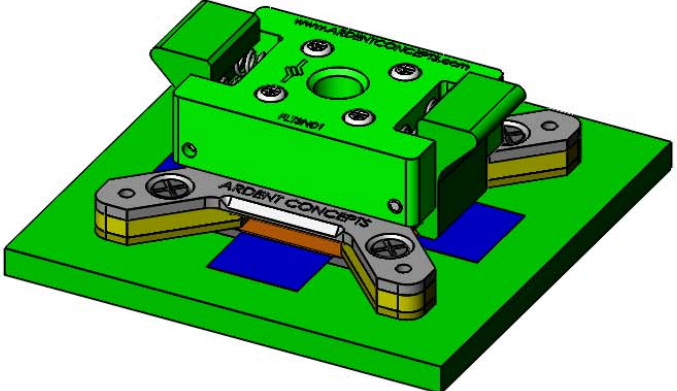
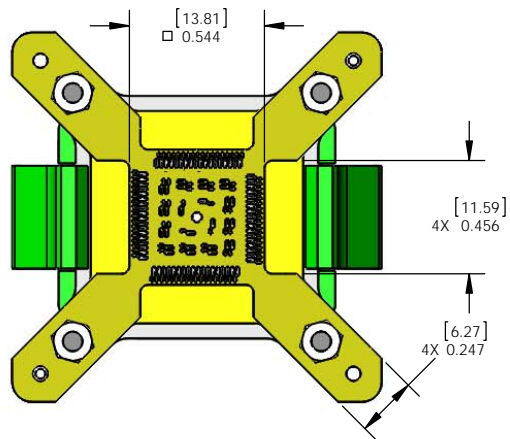

|   |      |              |   |  |
|---|------|--------------|---|--|
| INCH<br>UNLESS OTHERWISE SPECIFIED.   |      | DRAWN<br>DJI | DATE<br>8/2/11  | <br>4 MERRILL INDUSTRIAL DR, SUITE 102<br>HAMPTON, NH 03842<br>(603) 926-2517 |
| TOLERANCES:<br>ANGLES: ± 3 X.XX = ± .005<br>X.XXX = ± .002<br>X.XXXX = ± .001 |      | CHECKED      | ENG APPR  |  |
| CHANGE  | NOTE | PROJECTION   | SIZE<br><b>B</b>  | TITLE:<br>10X10, 72LD, 0.50mm SOCKET ASSEMBLY  |
| MATERIAL  | ---  |              | INTERPRET GEOMETRIC<br>TOLERANCING PER:<br>ANSI Y14.5M 1982 | DWG. NO.<br>FSK10X1072SN0501   |
| FINISH  | ---  |              | WWW.ARDENTCONCEPTS.COM                                      | SCALE: 2:1   |
|   |      |              | WEIGHT:   | SHEET 2 OF 2   |

D

C

B

A

D

C

B

A

8

7

6

5

4

3

2

1