

REVISIONS			
REV.	DESCRIPTION	DATE	APPROVED
B	RELEASED, ECN11-0688	4/18/11	DJI

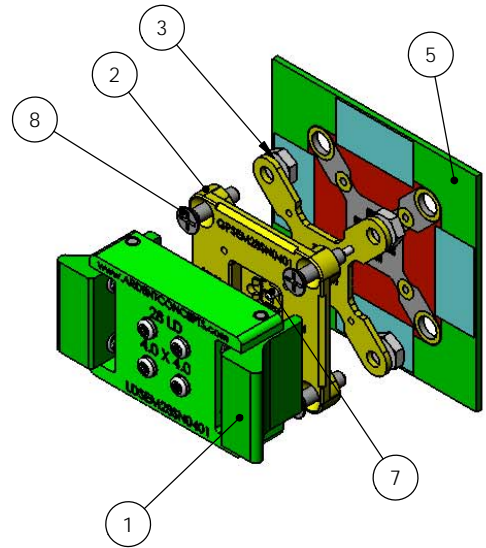
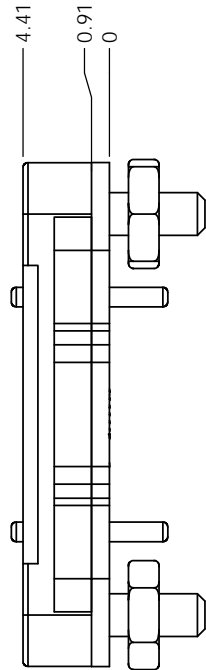

ITEM NO.	PART NUMBER	DESCRIPTION	Default/ QTY.
1	LDSEM28SN0401	HAND TEST LID	REF
2	GPSEM28SN0401	GUIDE PLATE	1
3	INSEM28SN0401	INSULATOR	1
4	SCSEM28SN0401	SHIPPING COVER	1
5	FPSEM28SN0401	FOOTPRINT SPECIFICATION	REF
6	SC04-03	.40mm RC SCRUB-R BECU	32
7	M10DP08	M1.0 DOWEL PIN X 8mm	2
8	256FHCS0375	2-56 FLAT HEAD SCREW	4
9	256NUT	2-56 NUT	4

METRIC UNLESS OTHERWISE SPECIFIED. TOLERANCES: ANGLES: ± 3° X.X ± 1 X.XX ± 0.05 X.XXX ± 0.025		DRAWN: DJI DATE: 4/18/11 CHECKED: ENG APPR:	 ARDENT CONCEPTS <small>Industrial and Test Equipment Div. of...</small> 4 MERRILL INDUSTRIAL DR, SUITE 102 HAMPTON, NH 03842 (603) 926-2517
CHANGE MATERIAL FINISH: ---	TITLE: B SOCKET ASSEMBLY DWG. NO. SKSEM28SN0401 INTERPRET GEOMETRIC TOLERANCING PER: ANSI Y14.5M 1982	REV: B SCALE: 4:1 SHEET 1 OF 1	