

**PROPRIETARY AND CONFIDENTIAL**  
 THE INFORMATION CONTAINED IN THIS DRAWING IS THE SOLE PROPERTY OF ARDENT CONCEPTS, INC. ANY REPRODUCTION IN PART OR AS A WHOLE WITHOUT THE WRITTEN PERMISSION OF ARDENT CONCEPTS, INC. IS PROHIBITED.

REVISIONS			
REV.	DESCRIPTION	DATE	APPROVED
A	RELEASED; ECN11-0797	6/30/11	DJI

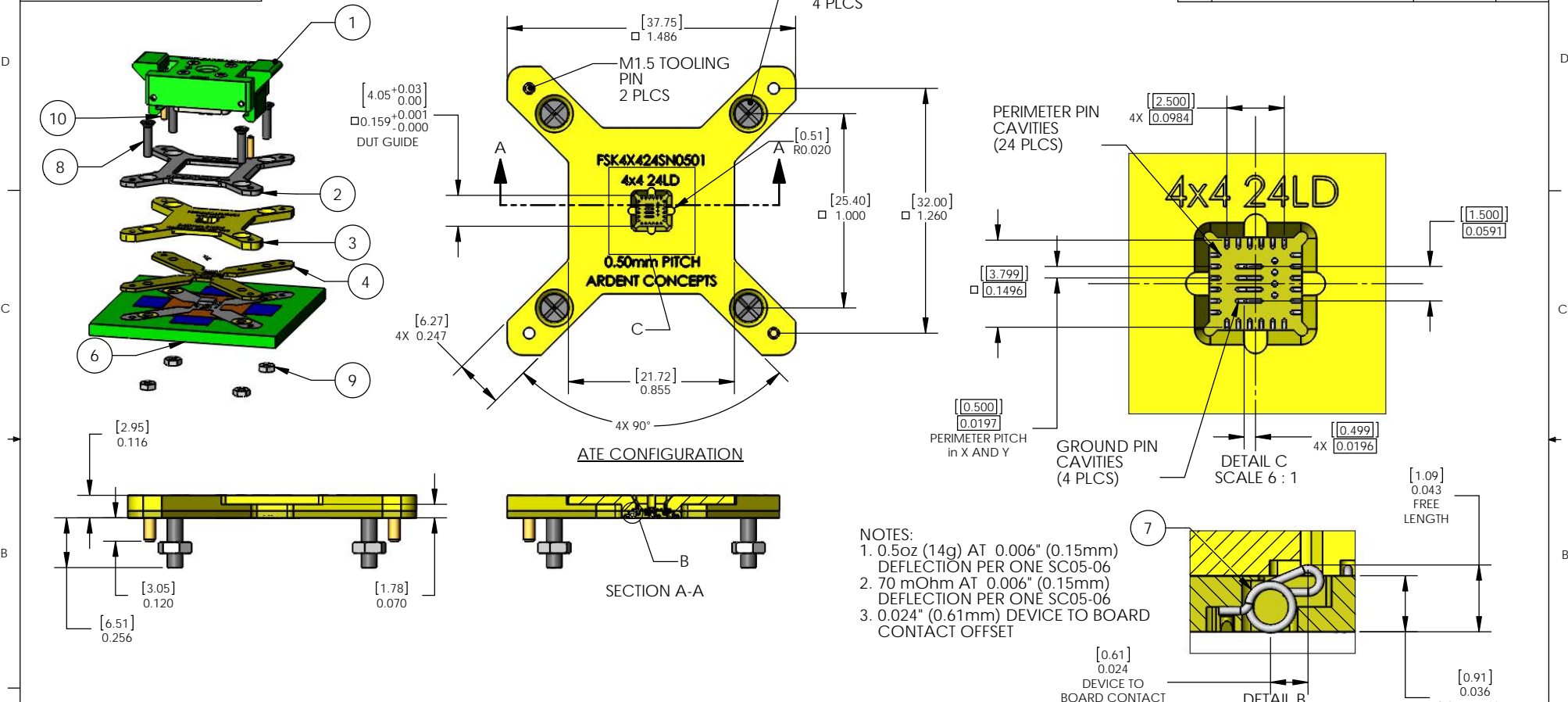

ITEM NO.	PART NUMBER	DESCRIPTION	Material	Default/QTY.
1	FLD4X4SN01	HAND TEST LID	REF	REF
2	FAPSN01	ADAPTER PLATE	303 STAINLESS STEEL	1
3	FGP4X424SN0501	GUIDE PLATE	TORLON 4203	1
4	FIN4X424SN0501	INSULATOR	TORLON 4203	1
5	FSCSN01	SHIPPING COVER	ESD LEXAN	1
6	FFP4X424SN0501	FOOTPRINT SPECIFICATION	REF	REF
7	SC05-06	.5mm .005" RC Scrub-R	SEMI PRECIOUS ALLOY	28
8	M20FHCS08	M2 FLAT HEAD X 8mm	18-8 STAINLESS STEEL	4
9	M20NUT	M2 NUT	18-8 STAINLESS STEEL	4
10	M15DP06	M1.5 X 6mm DOWEL PIN, 9159A005	HARDENED STEEL	2

<b>INCH</b> UNLESS OTHERWISE SPECIFIED. TOLERANCES: ANGLES: ± 3    X.XX = ± .005 X.XXX = ± .002 X.XXXX = ± .001		DRAWN: DJI    DATE: 4/27/11 CHECKED: ENG APPR:	<b>ARDENT CONCEPTS</b> <small>Manufacturing and Test Equipment Division</small> 4 MERRILL INDUSTRIAL DR, SUITE 102 HAMPTON, NH 03842 (603) 926-2517
CHANGE: [Symbol] [Symbol] [Symbol] [Symbol] MATERIAL: --- FINISH: ---	SIZE: <b>B</b> TITLE: 4X4, 24LD, 0.50mm SOCKET ASSEMBLY	INTERPRET GEOMETRIC TOLERANCING PER: ANSI Y14.5M 1982 DWG. NO. <b>FSK4X424SN0501</b> REV <b>A</b>	
WWW.ARDENTCONCEPTS.COM    SCALE: 2:1    WEIGHT:    SHEET 1 OF 2			

**PROPRIETARY AND CONFIDENTIAL**  
 THE INFORMATION CONTAINED IN THIS DRAWING IS THE SOLE PROPERTY OF ARDENT CONCEPTS, INC. ANY REPRODUCTION IN PART OR AS A WHOLE WITHOUT THE WRITTEN PERMISSION OF ARDENT CONCEPTS, INC. IS PROHIBITED.

REVISIONS			
REV.	DESCRIPTION	DATE	APPROVED
A	RELEASED; ECN11-0797	6/30/11	DJI

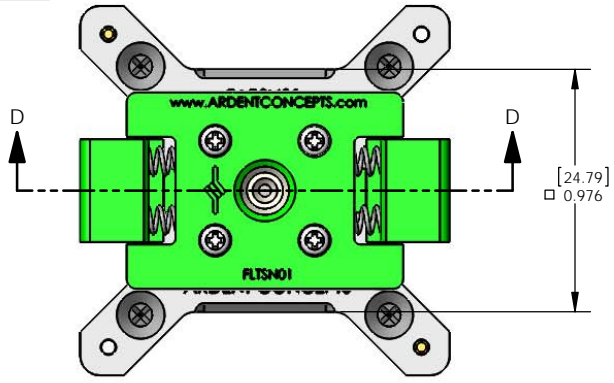

BENCH TEST CONFIGURATION

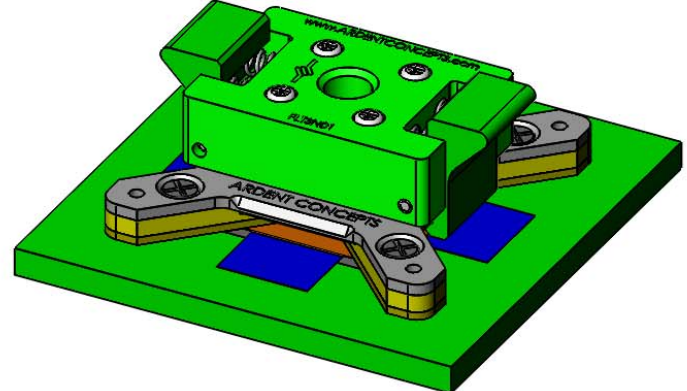
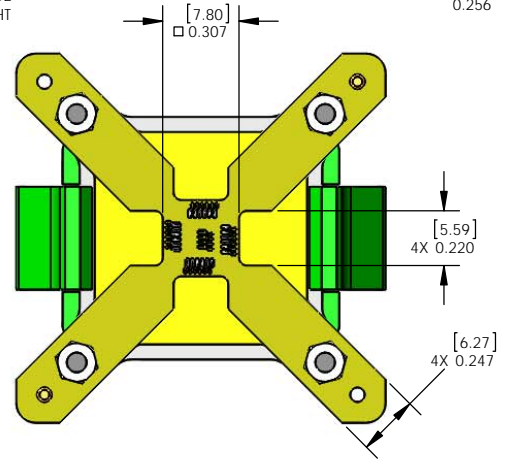
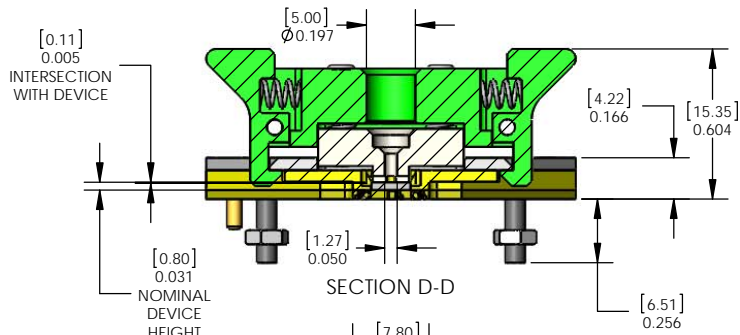

<b>INCH</b> UNLESS OTHERWISE SPECIFIED. TOLERANCES: ANGLES: ±3 X.XX = ±.005 X.XXX = ±.002 X.XXXX = ±.001		DRAWN: DJI DATE: 4/27/11 CHECKED: ENG APPR:	 <b>ARDENT CONCEPTS</b> <small>Industrial and Test Equipment Div., Inc.</small> 4 MERRILL INDUSTRIAL DR, SUITE 102 HAMPTON, NH 03842 (603) 926-2517
CHANGE: MATERIAL NOTE: --- FINISH: ---	SIZE: <b>B</b> TITLE: 4X4, 24LD, 0.50mm SOCKET ASSEMBLY DWG. NO. FSK4X424SN0501 INTERPRET GEOMETRIC TOLERANCING PER: ANSI Y14.5M 1982	REV: <b>A</b> SCALE: 2:1 WEIGHT: SHEET 2 OF 2	