

**PROPRIETARY AND CONFIDENTIAL**  
 THE INFORMATION CONTAINED IN THIS DRAWING IS THE SOLE PROPERTY OF ARDENT CONCEPTS, INC.. ANY REPRODUCTION IN PART OR AS A WHOLE WITHOUT THE WRITTEN PERMISSION OF ARDENT CONCEPTS, INC. IS PROHIBITED.

REVISIONS			
REV.	DESCRIPTION	DATE	APPROVED
A	RELEASED, ECN10-0599	07/29/10	SD

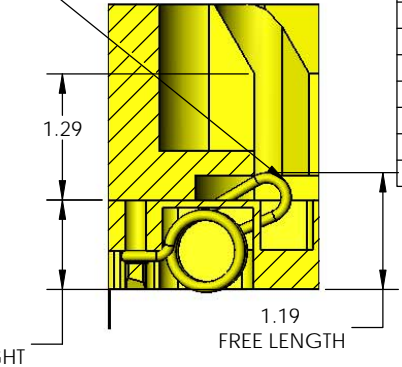
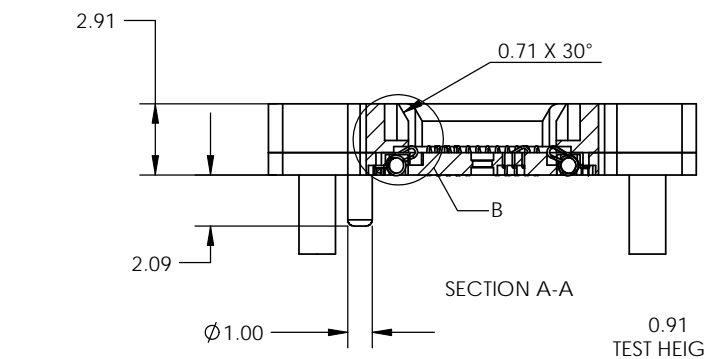
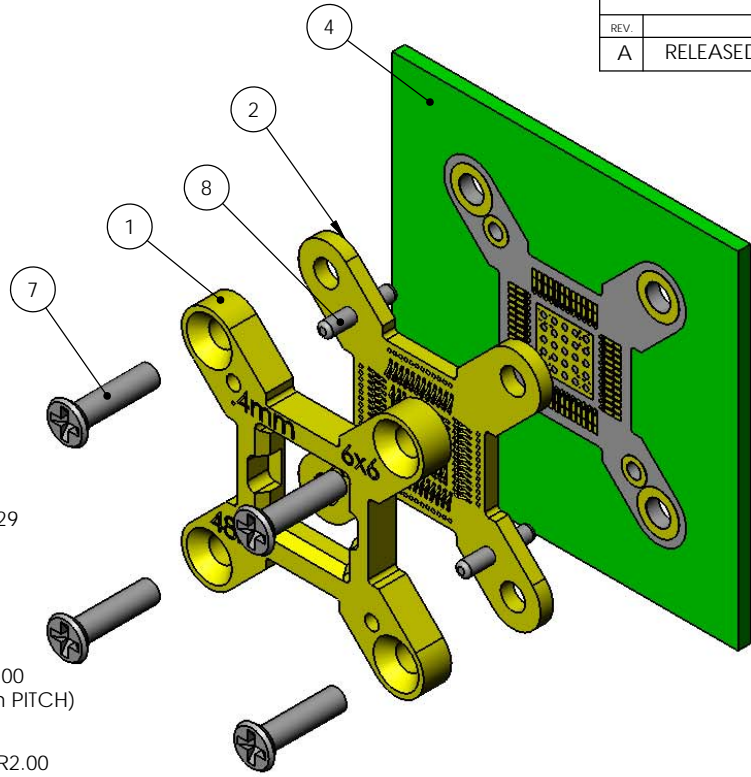
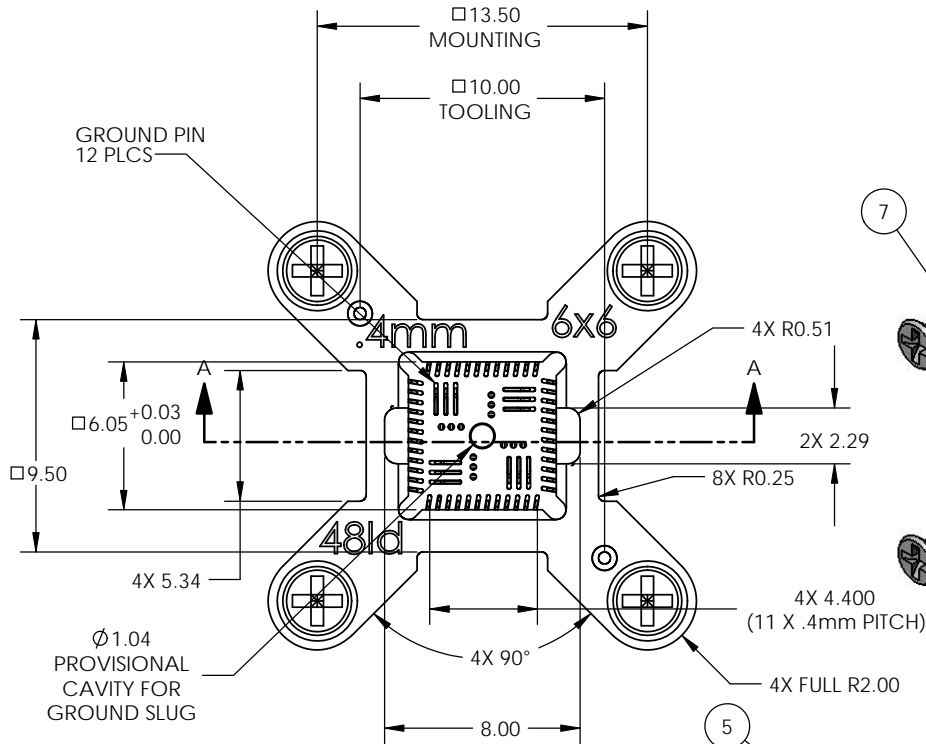

DETAIL B  
SCALE 20 : 1

ITEM NO.	PART NUMBER	DESCRIPTION	Default/ QTY.
1	GPMAC48SN0401	GUIDE PLATE	1
2	INMAC48SN0401	INSULATOR	1
3	SCMAC48SN0401	SHIPPING COVER	1
4	FPMAC48SN0401	FOOTPRINT SPECIFICATION	REF
5	SC04-03	.40mm RC SCRUB-R BECU	60
7	O80FHCS0250	0-80 FLAT HEAD X .250	4
8	M10DP05	M1 DOWEL PIN X 5mm	2

**METRIC**  
 UNLESS OTHERWISE SPECIFIED:  
 TOLERANCES:  
 ANGLES: ± 3    XX = ± 1  
                   XXX = ± .05  
                   XXXX = ± .02

DRAWN: SD    DATE: 06/15/10  
 CHECKED: \_\_\_\_\_  
 ENG APPR: \_\_\_\_\_

**ARDENT CONCEPTS**  
 4 MERRILL INDUSTRIAL DR., SUITE 102  
 HAMPTON, NH 03842  
 (603) 926-2517

SIZE: **B**    TITLE: SOCKET ASSEMBLY, 6mm, 48ld, .40mm PITCH

CHANGE MATERIAL FINISH: \_\_\_\_\_  
 NOTE: \_\_\_\_\_  
 PROJECTION: \_\_\_\_\_

INTERPRET GEOMETRIC TOLERANCING PER: ANSI Y14.5M 1982  
 DWG. NO.: SKMAC48SN0401    REV: A

WWW.ARDENTCONCEPTS.COM    SCALE: 5:1    WEIGHT:    SHEET 1 OF 1